



Audits/Inspections

Document Number INSP-2025-0001

Date of issue 07-Feb-2025

Done by: hariharan

Date of Inspection 07-Feb-2025

Auditee/Inspector Involved: hariharan

Overall Score: 75.00%

FAIL

Points which are extremely critical as regulatory compliance or CCP/OPRP

Target - To score at least 80% to pass the hygiene audit

| Section | Score | Percentage |
|--------------------|-------|------------|
| Hygiene Inspection | 45/60 | 75.00% |

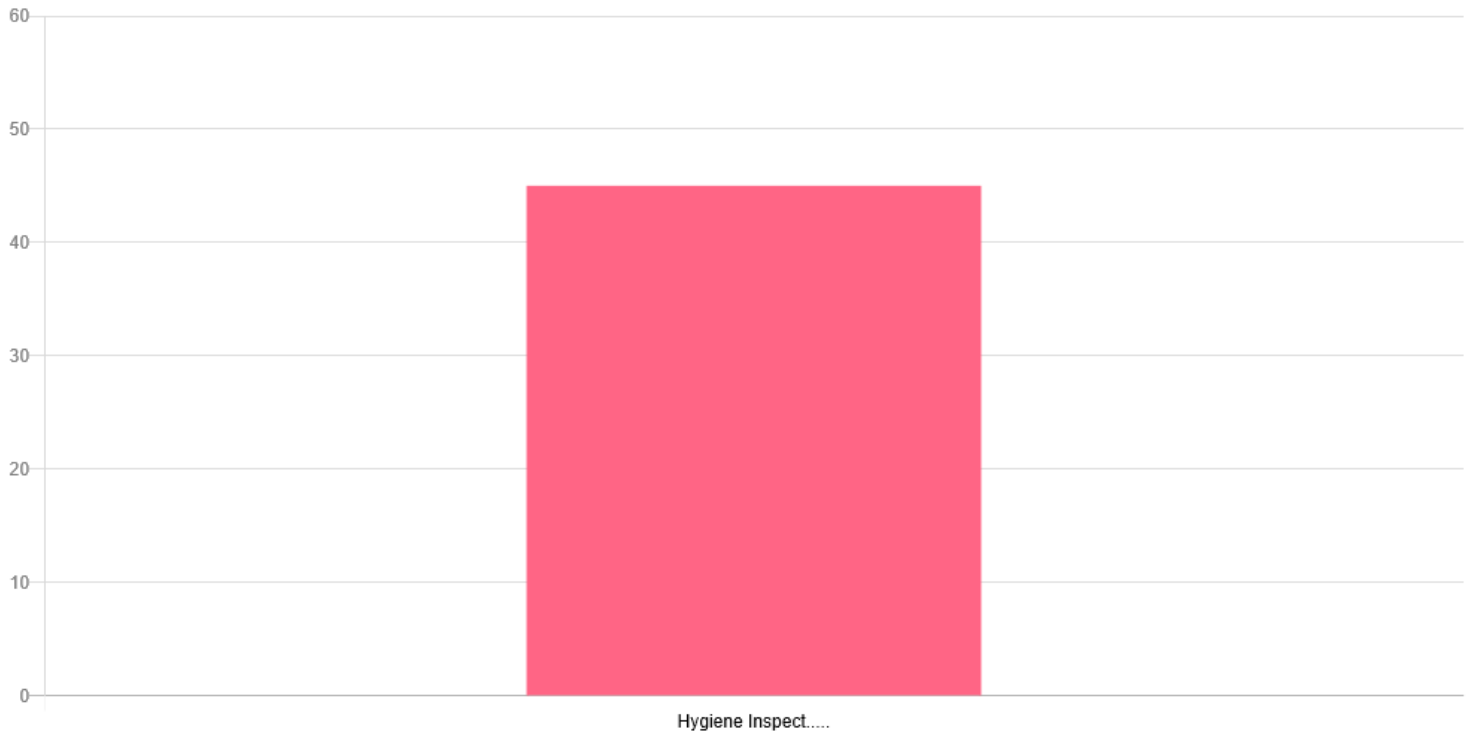

Audit Details

| Hygiene Inspection | | | |
|---|-------|----------|----------|
| Parameter | Score | Response | Comments |
| Hygiene Inspection | | | |
| Is the cleanliness and organization of workstations up to standard? | 5/5 | YES | |
| Is hygiene maintained on floors, walls, and restrooms? | 0/5 | NO | |



Audits/Inspections

Document Number INSP-2025-0001

Date of issue 07-Feb-2025

Done by: hariharan

Date of Inspection 07-Feb-2025

Auditee/Inspector Involved: hariharan

| | | | |
|--|-----|--------------------------|------------------------------|
| Has waste been properly disposed of, and bins cleaned? | 5/5 | YES | Design |
| Do employees comply with uniform and hygiene requirements? | 0/5 | NO | |
| Are handwashing stations stocked and functional? | 0/5 | NO | Issue in handwashing station |
| Is the condition of tools and equipment satisfactory? | 5/5 | YES | |
| Are emergency exits accessible and unobstructed? | 5/5 | YES | |
| Does safety equipment (e.g., fire extinguishers, alarms) meet operational standards? | 5/5 | YES | |
| Do storage conditions meet temperature and labeling guidelines? | 5/5 | YES | |
| Are pest control measures implemented effectively? | 5/5 | YES | |
| Does the lighting and ventilation ensure a safe and comfortable environment? | 5/5 | YES | |
| Have inspection logs and compliance records been updated? | 5/5 | YES | |
| Share any additional observations or feedback from the inspection. | | Observation and feedback | |



Audits/Inspections

Document Number INSP-2025-0001

Date of issue 07-Feb-2025

Done by: hariharan

Date of Inspection 07-Feb-2025

Auditee/Inspector Involved: hariharan

Enter the date and time of the inspection.

Date 07/02/2025

Time 18:11:49

| Date | Responsible | Signature | Observation | Status |
|---------------------|-------------|---|-----------------------|----------|
| 2025-02-07T18:11:00 | hariharan |  | Observation Completed | Approved |

Task(NC) Details

Hygiene Inspection

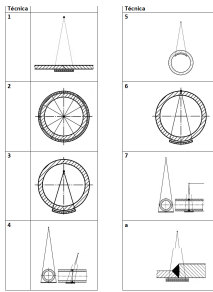
| Question | Comments | Assign To | Image Ref |
|---|----------|-----------|--|
| <p>Do employees comply with uniform and hygiene requirements?</p> <p>34465 - Techares task</p> | | hariharan |  |

Annexure

| Hygiene Inspection | | |
|---------------------|-------|-------------|
| Checklist Questions | Image | Observation |
| | | |



Audits/Inspections

Document Number INSP-2025-0001

Date of issue 07-Feb-2025

Done by: hariharan

Date of Inspection 07-Feb-2025

Auditee/Inspector Involved: hariharan

Are handwashing stations stocked and functional?

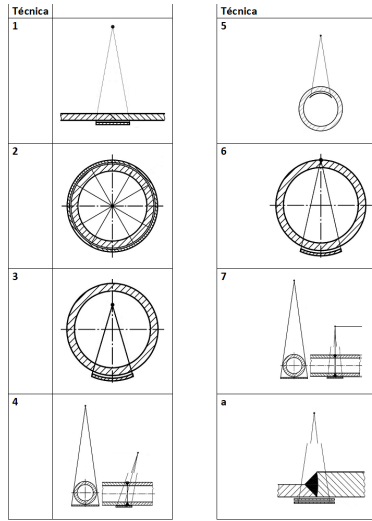

Issue in handwashing station

Has waste been properly disposed of, and bins cleaned?

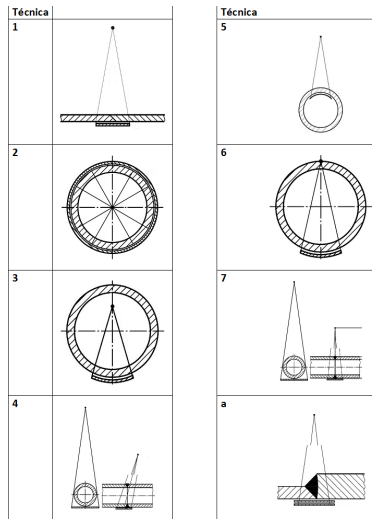

Design